

TW SERIES HEAVY DUTY TRAILING WIRE FLOW SWITCH

FEATURES

- Unique trailing wire sensor
- 0 to 500V AC 15 Amp S.P.D.T switch
- Reed switch versions available
- 316 Stainless steel or Polypropylene models
- 3/4" & 1" BSP & NPT models available
- Suits open channels or pipework
- Manual override built in
- Modular construction
- 200 Bar pressure rating
- Seal-less magnetic drive
- Weatherproof IP67 housing
- Easily serviceable

The TW Series heavy duty flow switches use a flexible stainless wire sensor rather than a conventional paddle to sense flow. They are suitable for sensing flow in open discharge applications or in pipes of any diameter from 50 mm upwards. The flexible stainless wire sensor offers major advantages over conventional paddles in applications where solids or semi solids are present, such as in sewage pumping. They are also suitable for use in slurry and mining applications and in many normal pumping situations where the flow velocity is high and conventional paddles are unsuitable.



ORDERING

TW21 - S - R - BSP - 100

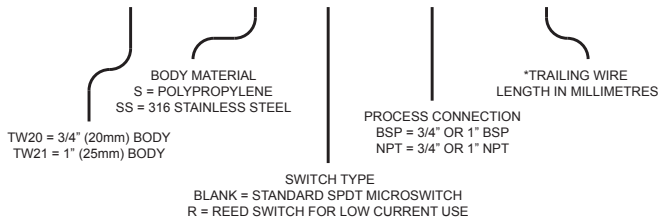

*Available Wire Lengths: 50mm, 80mm, 100mm, 140mm, 160mm, 180mm, 200mm, 250mm, 300mm

Please Note: Subject to 120 piece minimum order quantities, Stainless body NPT thread versions of the above models are available.

DIAGRAM

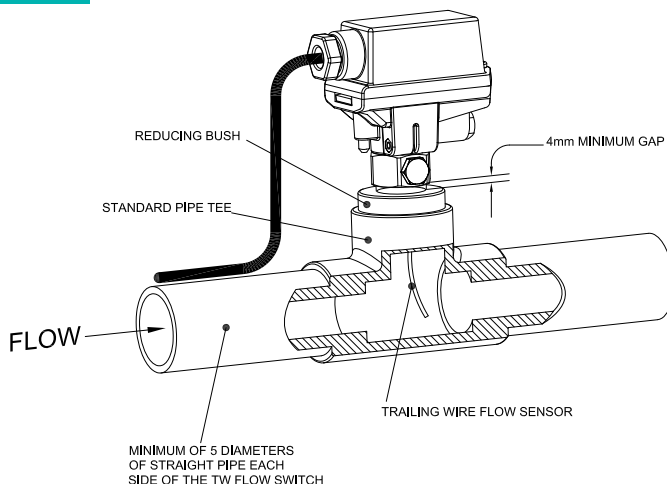

OUTLINE

The TW Series trailing wire flow switch is available in two basic models, an all Polypropylene version and a Polypropylene / 316 stainless version. Both versions are available with either a 3/4" or 1" male process connection in either BSPT or NPT. In addition, both versions are also available with either a Single Pole Double Throw (S.P.D.T) microswitch for general control circuit applications, or with an S.P.D.T reed switch, suitable for low voltage PLC and telemetry applications.

The electrical module of the TW Series flow switch is completely separate from the process connection and wet end of the switch. The wet end assembly and the electrical module lock together with a single externally accessible screw. This feature allows the flow switch to be disassembled and unscrewed from pipework without the need to disturb electrical wiring. A unique feature of the standard TW Series flow switch is its built in manual override. This allows the flow switch to be switched on at any time at the press of a button regardless of lack of flow. Using the manual override allows the system to be manually started at any time by simply pressing the button. It also makes the testing and commissioning of systems very simple. Please note: when supplied with a reed switch, no manual override is included in the TW Series flow switch.

The TW Series trailing wire flow switch is available with wire sensors in various lengths from 50mm to 300mm. The required wire length must be specified when ordering. The optimum wire length for a specific application can be obtained using our online calculator. The calculator can be accessed at <http://www.kelco.com.au/paddle-trimming-calculator-2>

TW SERIES

OPERATING LIMITATIONS

| Switch Model | TW-S (Polypropylene Switch) | TW-SS (316 Stainless) |
|--|-----------------------------|-----------------------|
| Maximum operating pressure (Static or dynamic) at ambient temperature. | 18 Bars (261 PSI) | 200 Bars (2900 PSI) |
| Minimum burst pressure at ambient temperature | 45 Bars (652 PSI) | 500 Bars (7251 PSI) |
| Maximum operating temperature (Liquid) | 60°C See Note Below | 80°C |
| Minimum operating temperature (Liquid) | -20°C | -20°C |
| Ingress protection rating (Waterproof rating) | IP67 | IP67 |

Please note: Maximum operating pressure of the Polypropylene TW-S must be linearly de-rated as operating temperature is increased so that at 60°C the maximum permissible operating pressure for the switch does not exceed one Bar absolute.

ELECTRICAL DATA

| RATED VOLTAGE | NON INDUCTIVE LOADS | | | | INDUCTIVE LOADS | | | |
|---------------|---------------------|------|-----------|-------|-----------------|-------|------------|----|
| | RESISTIVE LOAD | | LAMP LOAD | | INDUCTIVE LOAD | | MOTOR LOAD | |
| | NO | NC | NO | NC | NO | NC | NO | NC |
| 125 VAC | 15A | 3A | 1.5A | 15A | 5A | 2.5A | | |
| 250 VAC | 15A | 2.5A | 1.25A | 15A | 3A | 1.5A | | |
| 500 VAC | 10A | 1.5A | 0.75A | 6A | 1.5A | 0.75 | | |
| 8 VDC | 15A | 3A | 1.5A | 15A | 5A | 2.5A | | |
| 14 VDC | 15A | 3A | 1.5A | 10A | 5A | 2.5A | | |
| 30 VDC | 6A | 3A | 1.5A | 5A | 5A | 2.5A | | |
| 125 VDC | 0.5A | 0.5A | 0.25A | 0.05A | 0.05A | 0.05A | | |
| 250 VDC | 0.5A | 0.5A | 0.25A | 0.03A | 0.03A | 0.03A | | |

SPARE PARTS

The TW Series trailing wire flow switches are very simple to service, and most components are available in spare part kits.

HAZARDOUS APPLICATIONS

The TW Series trailing wire flow switch can be used in hazardous areas. The flow switch is classed as a simple device and does not contain components capable of storing or producing an electric charge. As a simple device the TW Series can be used in hazardous applications provided it is isolated by an intrinsically safe barrier, a zener barrier.

ELECTRICAL DATA REED SWITCH MODELS

Reed switch models are supplied with a high compliance single pole double throw reed switch suitable for all low wetting current and low voltage applications. Such applications include PLC control, signalling in telemetry systems and relay logic circuits. Note: the reed switch models are not suitable for use with inductive loads such as contactors or high wattage relays.

APPROVED STANDARDS

The high compliance single pole double throw switch used in the TW Series flow switch is approved to the following international standards: UL (File No. E32667), CSA (File No. LR21642) SEV (File No. S20/163), CE.

| SWITCH TYPE | CONTACT | SWITCHED POWER | SWITCHED VOLTAGE MAXIMUM | SWITCHED CURRENT (RESISTIVE) | CARRY CURRENT | BREAKDOWN VOLTAGE | TYPICAL APPLICATIONS |
|-------------------------|---------------------------|------------------|--------------------------|------------------------------|---------------|-------------------|---|
| DRY CONTACT REED SWITCH | S.P.D.T BREAK BEFORE MAKE | 20W /V A MAXIMUM | 140V AC 150V DC | 1 AMP MAXIMUM | 2 AMP MAXIMUM | 200V MINIMUM | PLC, TELEMETRY & GENERAL LOW VOLTAGE CONTROL APPLICATIONS |

DIMENSIONS

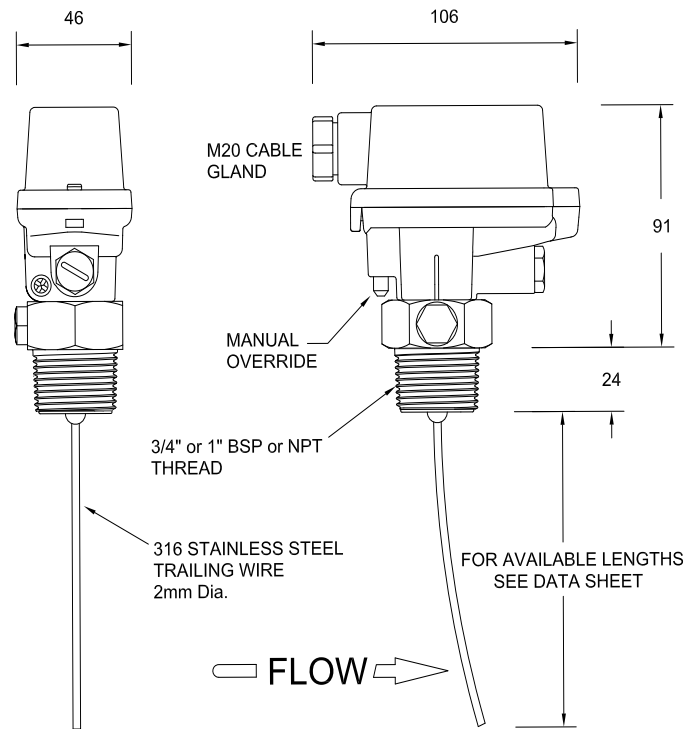

KELCO Engineering Pty Ltd

ABN 20 002 834 844 Head office and factory: 9/9 Powells Road Brookvale NSW 2100 Australia. Postal Address: PO Box 7485 Warringah Mall Post Shop Brookvale NSW 2100 Australia. Phone: +61 2 9905 6425 Fax: +61 2 9905 6420 Email: Sales@kelco.com.au Web: www.Kelco.com.au

PLEASE NOTE: Kelco Engineering Pty Ltd reserves the right to change the specification of this product without notice. Kelco Engineering Pty Ltd accepts no liability for personal injury or economic loss as a consequence of the use of this product. All rights reserved copyright Kelco Engineering Pty Ltd © 2014 The Kelco TW Series is protected by a 12 month return to base warranty. Full details of our warranty can be downloaded from: <http://www.kelco.com.au/warranty>