

# ULTRASWITCH P20 SERIES

## CORROSION RESISTANT IN LINE FLOW SWITCHES



Magnetically sprung piston provides exceptional reliability

### FEATURES

- SUITS TUBES & PIPES 6 TO 20 MM (1/4" TO 3/4") DIA.
- NO METAL PARTS IN CONTACT WITH LIQUIDS
- ALL POSITION MOUNTING
- CHOICE OF 3 SWITCHING FLOW RATES
- DETECTS VERY LOW FLOWS
- ROBUST RELIABLE SWITCH
- EASY TO INSTALL
- HIGH FLOW THROUGH
- 18 BAR (260 PSI) PRESSURE RATING
- VERY LOW HEAD LOSS
- MANY OPTIONS AVAILABLE

### APPLICATIONS

- Liquid or gas flow detection
- Constant pressure pump control
- Loss of prime pump protection
- Water treatment control
- Industrial process control
- Irrigation control
- Chemical dosing systems
- Chilled water control
- Vapour flow detection



HORIZONTAL MOUNTING



VERTICAL MOUNTING



AUSTRALIAN MADE

# GENERAL INFORMATION

## DESCRIPTION

The P20 In line Flow Switch is a simple and reliable flow switch that can detect the flow of liquids or gases in tubes and small diameter pipes. The P20 can detect either continuous or pulsed flows. Typical applications include monitoring flow in water treatment and irrigation systems, domestic constant pressure system control, gland cooling systems and a myriad of uses in industrial process control. The P20 flow switch gives a simple on or off response to liquid flow. There are no metal parts in contact with liquids within the switch, so the P20 is ideal for use in

aggressive liquids such as seawater, groundwater, acids and many chemical solutions. The standard switch is supplied complete with pipe spigots and unions, for direct fitting into PVC or ABS pipe work. In addition 6 electrical modules are available that give a wide choice of control options. These include electrical modules with single and multiple reed switches, relays with various coil voltages, and solid-state switches. Each P20 flow switch is supplied complete with 3 pistons, to provide the user with a wide choice of flow switching points.

## OPERATING PRINCIPLE

The body of the P20 flow switch houses a fluted piston. Any flow, either pulsed or continuous, causes the piston to be pushed back within the switch body to a point where the liquid can pass over the piston and out of the switch. The piston contains a magnet that actuates a reed switch and this provides the switching output. When flow stops, the piston is pushed back to the off position by a second magnet built into the switch body. No

metal parts are in contact with the process liquid, and the magnetically sprung piston provides an exceptionally reliable corrosion proof mechanism. The sensitivity of the flow switch and its switching point are determined by the viscosity of the fluid and by the clearance between the piston and the switch body. The P20 flow switch can be mounted in any orientation in pipe-work, including upside down, with no adverse effects.

## CONSTRUCTION

The standard P20 flow switch is made from glass reinforced polypropylene and ABS, with neoprene o-ring seals. The piston return mechanism and the electrical switching action within the switch are achieved using high power magnets operating through the solid body of the switch. The electri-

cal housing is hose-proof & weatherproof, and is supplied with a built in 20mm cable gland, for conduit or flexible cable entry. The electrical circuit boards used in the switch are interchangeable, and all of the parts of the P20 flow switch are available as spare parts.

## OPTIONS

In addition to a choice of 6 standard circuit boards to suit the P20 flow switch; the user also has the following options.

Each P20 flow switch is supplied complete with 3 pistons. By simply changing pistons the user has the choice of 3 switching points, 140 millilitres per minute, 570 millilitres per minute or 1.70 Litres per minute. In addition, for OEM applications, switches can be ordered pre-set to any required switching

point from one Litre per hour to 4 Litres per minute. Contact your supplier for details.

The standard P20 flow switch is supplied complete with inlet and outlet pipe connections with 20mm (3/4 BSP) male threads and unions. Pipe spigots in 15 nominal size are also included. In addition, the P20 flow switch can also be ordered with optional 25mm (1" BSP) unions and 20mm (3/4") nominal size spigots, in PVC or ABS.

MADE IN AUSTRALIA BY

## **KELCO ENGINEERING**

*Manufacturing division of CYNCARD PTY LTD A.B.N. 20 002 834 844*

*Head Office and Factory: 2/9 Powells Road BROOKVALE 2100 AUSTRALIA*

*Postal Address: PO Box 496 BROOKVALE NSW 2100*

*Phone: 61 2 (02) 9905 6425 Fax: 61 2 (02) 9905 6420*

*Email: kelco@wr.com.au URL: <http://www.kelco.com.au>*

PLEASE NOTE: Cyncard Pty Ltd reserves the right to change the specification of this product without notice. Cyncard Pty Ltd accepts no liability for personal injury or economic loss as a consequence of the use of this product. All rights reserved copyright Cyncard Pty Ltd © 2001.  
Please note the P20 flow switch is the subject of PCT international patent applications.

# P20 SERIES IN LINE FLOW SWITCH TECHNICAL DATA

The P20 In Line Flow Switch is a versatile and adaptable flow switch that lends itself to a myriad of applications ranging from low flow detection in chemical metering systems through to domestic constant pressure pump control. The following technical data is principally intended to assist system designers and process engineers with details of the most common parameters of the product.

## NOMENCLATURE

### EXAMPLE: P20-B-A-20-PVC

P20 FLOW SWITCH WITH SINGLE REED SWITCH CIRCUIT BOARD, NORMALLY OFF, SWITCHES ON AT 0.14 LITRES PER MINUTE ON A RISING FLOW, 20mm (3/4BSP) UNIONS AT BOTH ENDS AND 15 N/B PVC SPIGOTS PROVIDED.

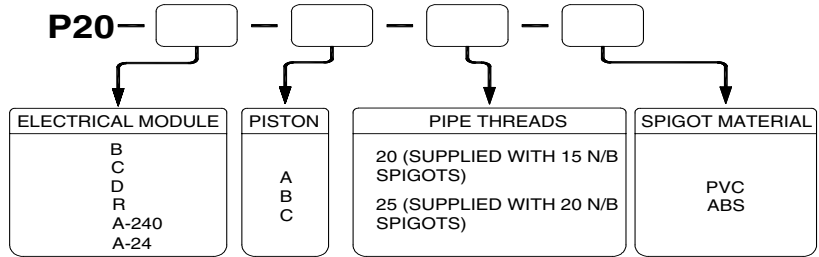

## CONSTRUCTION MATERIALS

The P20 In Line Flow Switch has no metal parts in contact with the process fluid. The only materials in contact with fluid passing through the switch are glass-reinforced polypropylene, and neoprene (O-rings). The working action of the switch is achieved using high power permanent magnets operating through the solid glass reinforced polypropylene body of the switch. The electrical housing is made from ABS, and the pipe spigots supplied with the switch are available in either PVC or ABS

The graph below sets out the dynamic head loss across the P20 flow switch. The graph data refers to water at 15°C as the test medium.

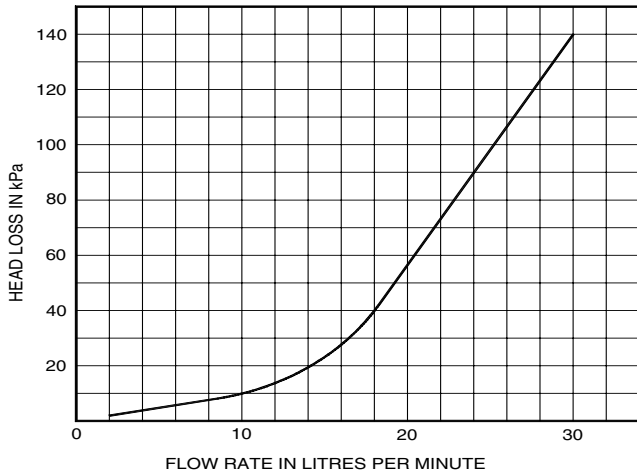

## DIMENSIONS

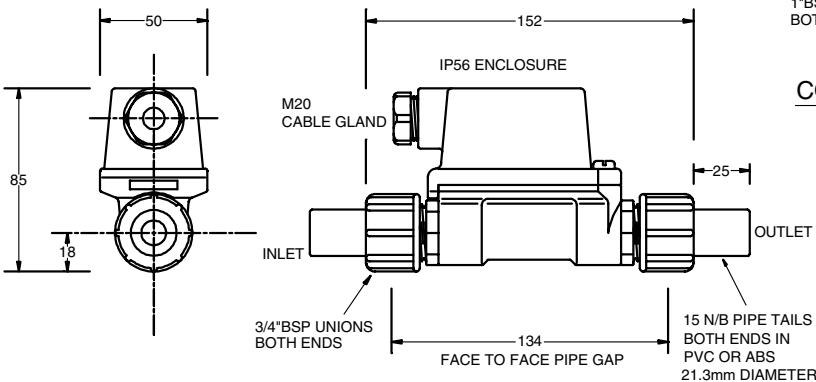

CONFIGURED FOR 15mm NOMINAL BORE PIPE

## OPERATING ENVIRONMENT

Maximum Operating Pressure (Static or Dynamic) at Ambient Temperature	1800 Kpa (260 P.S.I.)
Minimum Burst Pressure at Ambient Temperature	9700 Kpa (1400 P.S.I.)
Maximum Liquid Temperature (Standard P20 Switch)	80°C
Minimum Liquid Temperature (Standard P20 Switch)	-30°C
Maximum Recommended Continuous Flow Rate (Water)	25 Litres per Minute Dynamic head loss across the switch <100kPa
Liquid Ph range	1 to 14
Ingress Protection Rating (Weatherproof Rating)	IP56 (Hose proof & weather proof)

**Important Note** Maximum operating pressure must be de-rated, in proportion to temperature increase, and in consideration of any chemical solutions being processed.

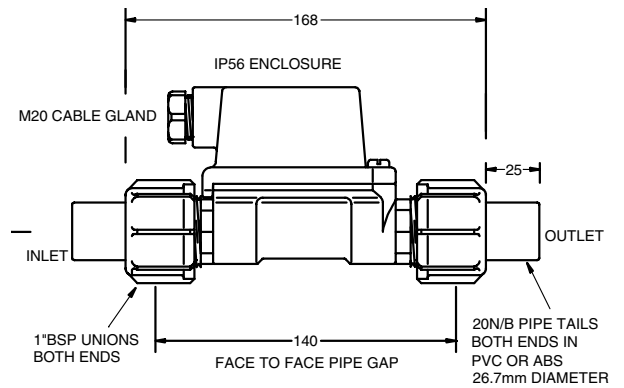

CONFIGURED FOR 20mm NOMINAL BORE PIPE

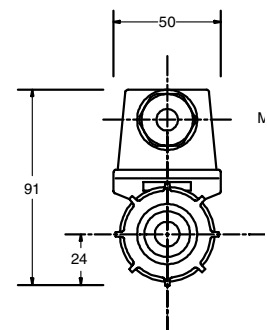

## FLOW SENSITIVITY & HYSTERESIS

Sensitivity to fluid flow is a direct function of liquid viscosity and piston clearance. There are 3 pistons available to suit the P20 flow switch. Each piston has a distinct switching point. The pistons are designated and marked A, B and C. The P20 Flow switch is supplied as standard with the "A" piston fitted. The optional "B" or "C" pistons are also supplied with each switch.

The following table sets out the performance parameters of the 3 pistons. The data is based on testing using water at 15°C as the test medium, and is accurate to +/-10%. Changes in liquid viscosity will affect the switching point. Increases in viscosity will proportionally decrease the flow rate required to actuate the switch, and will proportionally increase the response time. Decreasing viscosity will proportionally increase the flow rate required to actuate the switch, and will proportionally decrease the response time.

Piston Markings and Designation	Switching Point on a Slowly Rising Flow in Litres per Minute	Switching Point on a Slowly Reducing Flow in Litres per Minute	Electrical Response Time in Seconds After Cessation of Flow
A	0.140	0.065	0.4
B	0.570	0.370	0.3
C	1.700	1.330	0.2

**Please Note** The type "A" piston is supplied as standard fitted to each switch, unless otherwise specified. The B & C pistons are included packed in with each switch.

## ELECTRICAL DATA

The P20 In Line Flow Switch is available in a variety of electrical configurations, to suit specific applications. The model numbers and details of these options are outlined in the table below.

Switch Model	Module Type	Contact Configuration	Switched Power Maximum	Switched Voltage Maximum	Switched Current Resistive AC (rms) Maximum	Inductive Loads (Power Factor 0.4)	Typical Application
P20-B	Dry Reed Switch	S.P.S.T. N.O	40W	240V AC 200V DC	1A	Not Suitable	PLC and General Control Circuits
P20-C	Dry Reed Switch	S.P.D.T.	40W	240V AC 200V DC	1A	Not Suitable	PLC and General Control Circuits
P20-D	Dry Reed Switch	3 Pole Switch 3 by N.O	40W	240V AC 200V DC	1A	Not Suitable	Telemetry and local Control Circuits
P20-R	Solid State Relay (Triac)	S.P.S.T. N.O	750W	2 to 240V AC	4A Continuous (Spike to 16A)	4A at 240V AC	AC Control circuits and AC Motor Control to 1 HP
P20-A-240	Standard Relay 240V AC Coil	S.P.D.T.	2500VA at 250VAC 300VA at 30VDC	0 to 240 V AC	10A	7.5A at 240V AC 5A at 30V DC	General AC or DC Control
P20-A-24	Standard Relay 24V AC Coil	S.P.D.T.	2500VA at 250VAC 300VA at 30VDC	0 to 240V AC	10A	7.5A at 240V AC 5A at 30V DC	General AC or DC Control

**Note** The P20 In Line Flow Switch uses reed switches as the primary switching element. Reed switches are one of the most reliable mechanical switching devices ever devised. They offer an operating life in excess of 100 million cycles, however, care needs to be taken to ensure they are not electrically overloaded or if applied in questionable applications, suitable protection should be added to the control circuit.

## COMPONENT PARTS

The P20 In Line Flow Switch is a fully serviceable device. All of the component parts of the switch are available as spare parts, and many of the parts are interchangeable, these include the circuit boards, the pistons and the inlet and outlet adaptors and unions.

The interchangeability of components allows custom configuration of the switch. For example it is entirely practical to configure the P20 flow switch with a 25mm inlet thread and a 20mm outlet thread, or to configure the switch with the reverse of this arrangement. This flexibility can be achieved using the standard component parts of the switch.

## ADDITIONAL OPTIONS

The P20 flow switch can be supplied with 20 BSP (3/4" BSP) or 25 BSP (1" BSP) unions and 15mm or 20mm sockets or spigots in PVC or ABS. In addition, sets of tube flare fittings are available to suit the switch. These allow the switch to be installed in flexible poly tubing systems in 6 by 5mm, 8 by 4mm or 12 by 9mm sizes.

Switches are also available in materials of construction other than those outlined here. Contact your supplier with your specific requirements.

### PARTS LIST FOR P20 IN LINE FLOW SWITCH 25BSP UNION ASSEMBLY

All of the components of this switch are available as spare parts, as listed below.

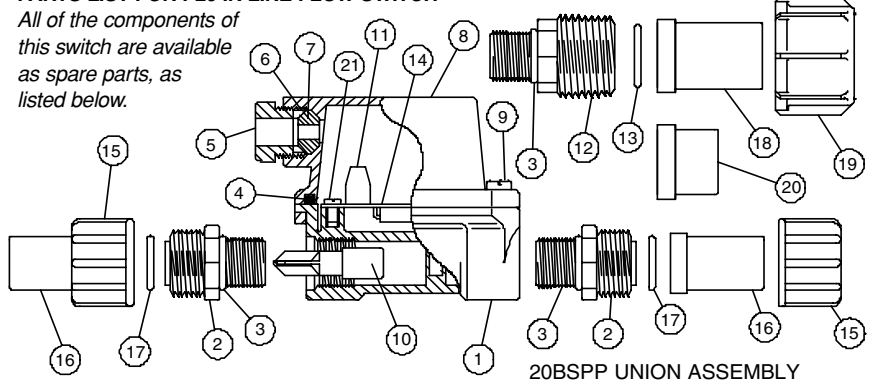

ITEM	DESCRIPTION	QTY	MATERIAL
1	SWITCH BODY	1	GLASS REINFORCED POLYPROPYLENE
2	M20 by 3/4BSP ADAPTOR	2	GLASS REINFORCED POLYPROPYLENE
3	No 018 O-RING	2	NEOPRENE
4	MAIN LID GASKET	1	SANOPRENE
5	CABLE GLAND NUT	1	HIGH IMPACT ABS
6	CABLE GLAND THRUST RING	1	HIGH IMPACT ABS
7	CABLE GROMMET	1	SANOPRENE
8	LID	1	HIGH IMPACT ABS
9	LID FIXING SCREW	1	M5 BY 16 STAINLESS STEEL TYPE 304
10	PISTON, MODEL A, B or C	1	GLASS REINFORCED POLYPROPYLENE
11	TERMINAL BLOCK	1	ACETAL RESIN
12	M20 by 1" BSP ADAPTOR	2	GLASS REINFORCED POLYPROPYLENE
13	No 117 O-RING SEAL	2	NEOPRENE
14	CIRCUIT BOARD ASSEMBLY	1	COMPLETE ELECTRICAL MODULE
15	20 mm BSP UNION NUT	2	GLASS REINFORCED POLYPROPYLENE
16	15 mm (1/2") PIPE SPIGOT	2	PVC OR ABS
17	No 115 O-RING SEAL	2	NEOPRENE
18	20mm (3/4") PIPE SPIGOT	2	PVC OR ABS
19	25mm BSP UNION NUT	2	GLASS REINFORCED POLYPROPYLENE
20	15mm (1/2") PIPE SOCKET	2	PVC OR ABS
21	CIRCUIT BOARD SCREW	2	M4 BY 6 STAINLESS TYPE 304

### MADE IN AUSTRALIA BY KELCO ENGINEERING

Manufacturing division of CYNCARD PTY LTD ABN 20 002 834 844

Head Office and Factory: 2/9 Powells Road BROOKVALE 2100 AUSTRALIA

Postal Address: PO Box 496 BROOKVALE NSW 2100 Phone: 61 2 (02) 9905 6425

Fax: 61 2 (02) 9905 6420 Email: kelco@wr.com.au

PLEASE NOTE Cyncard Pty Ltd reserves the right to change the specification of this product without notice. Cyncard Pty Ltd accepts no liability for personal injury or economic loss as a consequence of the use of this product. All rights reserved copyright Cyncard Pty Ltd © 2001. Please note the P20 flow switch is the subject of international patent applications.

# INSTALLATION AND OPERATING SHEET FOR P20 IN LINE FLOW SWITCH

**PLEASE READ THIS INSTALLATION SHEET CAREFULLY AND FULLY BEFORE INSTALLING THIS FLOW SWITCH**

## INTRODUCTION

The P20 flow switch is an in line piston flow switch that is supplied preset to switch on or off at a specific flow rate. The body of the switch contains a piston that obstructs the line of flow. To pass through the switch, the process fluid must push the piston back and flow over the piston and out through the outlet fitting. When fluid pushes the piston back, a magnet inside the piston actuates a reed switch in the electrical enclosure; this provides a set of closed, (or open) electrical contacts, which can be used in control circuits to indicate flow. The body of the P20 contains a fixed magnet that opposes the magnet in the piston. The repulsive force generated between the piston and body magnets constantly pushes the piston back to the off position, against the incoming flow. This unique magnet system negates the need for metal springs and provides the switch with exceptional reliability.

## OPERATING ENVIRONMENT

The P20 flow switch has no metal parts in contact with the process fluid. Inert thermoplastics are all that come in contact with the liquid passing through the switch. This means the P20 can be used in aggressive chemical solutions, seawater, and bore water and in many fluids that would attack metal parts. The P20 flow switch contains a close fitting piston, and should only be used in applications where the process fluid is reasonably clean and free of entrained or suspended material. Fluids containing large particulate matter, ferrous materials or fibrous matter should not be used in this switch. If the degree of contamination of the process fluid can't be guaranteed, then suitable line filtration should be fitted to the system upstream of the P20 flow switch.

The standard P20 flow switch is constructed from glass reinforced polypropylene, with neoprene o-rings, and an ABS electrical housing. The P20 flow switch is weatherproof to IP56, that is it is hose-proof and suitable for all outdoor exposed applications. The switch should be protected from freezing, or from exposure to fluid temperatures in excess of 80°C. The P20 flow switch should not be used in applications where the line pressure exceeds 18 bars, in the interest of safety, the switch has a burst pressure rating of >97 bars. Care should be taken not to expose the P20 switch to excess pressures such as may be generated by water hammer.

The environmental limitations of the standard P20 flow switch are set out in the following table.

Maximum Operating Pressure (Static or Dynamic) at Ambient Temperature	1800 Kpa (260 P.S.I.)
Minimum Burst Pressure at Ambient Temperature	9700 Kpa (1400 P.S.I.)
Maximum Liquid Temperature (Standard P20 Switch)	80°C
Minimum Liquid Temperature (Standard P20 Switch)	-30°C
Maximum Recommended Continuous Flow Rate (Water)	25 Litres per Minute
Liquid Ph range	1 to14

**Important Note:** Maximum operating pressure must be de-rated, in proportion to temperature increase, and in consideration of any chemical solutions being processed.

## INSTALLATION

The P20 flow switch can be mounted in any orientation in the pipe-work, including upside down. There is a direction of flow arrow on the switch body. This directionality must be adhered to, as the switch will not operate against a reversed flow. Pipe-work can be used to support the switch, or the switch can be connected directly into valve manifolds or pump ports.

## PIPE TERMINATION & SPIGOTS

There are a number of optional piping terminations available that may have been supplied with the P20 flow switch. These include tapered or parallel BSP male fittings, in 3/4" or 1" sizes. The parallel thread fittings are supplied with suitable union nuts, O-rings and pipe sockets or spigots. The taper thread adaptors are not supplied with unions, as they are intended to be screwed directly into pipe-work. Where parallel thread fittings and unions are supplied, a set of tube flare fittings to suit standard flexible tubing may also be included. The tube flare fittings accept flexible poly tubing in sizes 12 by 9, 8 by 4 and 6 by 5mm.

## FLOW SENSITIVITY & SWITCHING POINT

The P20 flow switch is supplied configured to switch at one of three possible flow rates. It is possible to alter the switching point of the flow switch, on site, simply by substituting one of the 2 alternate pistons. The piston fitted to a specific P20 flow switch can be identified by a letter, either A, B or C that is engraved on the conical nose of each piston. The "A" piston is supplied as standard fitted to the switch, and detects the lowest flow rate, 0.14 L/m, it is therefore the most sensitive. The "B" piston switches at 0.57 L/m, and the "C" piston is the least sensitive, and requires a flow of 1.70 L/m to actuate. Pistons are easily cleaned or replaced simply by unscrewing the inlet adaptor and removing the specific piston, a piston kit is included with each switch that contains the optional "B" and "C" pistons.

## ELECTRICAL

The electrical enclosure on the P20 switch is accessible by removing one screw on the lid. The lid has an integral 20mm cable gland designed to accept flexible cable up to 10mm diameter. If the gland nut is removed the exposed female thread will then accept a 20mm conduit bush. Various electrical options are available for the P20 flow switch. Details of the specific circuit board module, including its model number are located inside the lid of the electrical housing of each switch. All the available electrical modules use a reed switch as the primary switching element. The contacts of the reed switch open and close in response to the position of the switch piston magnet. The reed switch may be the primary switch, or

it may be used to drive a triac or a relay, that is included on the circuit board in the switch. Where the reed switch is used as the main switch, care should be taken to ensure it is not overloaded. Reed switches are very reliable devices but may be damaged easily if overloaded. Use interposing relays and avoid inductive loads, fit suitable protection such as diodes or rate effect suppression circuits. Avoid capacitive coupling effects associated with long cable runs, use shielded cable in such situations, and fit diode protection to the reed switches in DC applications.

*The table below sets out details of the various electrical modules, their model numbers and their electrical specifications.*

Switch Model	Module Type	Contact Configuration	Switched Power Maximum	Switched Voltage Maximum	Switched Current Resistive AC (rms) Maximum	Inductive Loads (Power Factor 0.4)	Typical Application
P20-B	Dry Reed Switch	S.P.S.T. N.O	40W	240V AC 200V DC	1A	Not Suitable	PLC and General Control Circuits
P20-C	Dry Reed Switch	S.P.D.T.	40W	240V AC 200V DC	1A	Not Suitable	PLC and General Control Circuits
P20-D	Dry Reed Switch	3 Pole Switch 3 by N.O	40W	240V AC 200V DC	1A	Not Suitable	Telemetry and local Control Circuits
P20-R	Solid State Relay (Triac)	S.P.S.T. N.O	750W	2 to 240V AC	4A Continuous (Spike to 16A)	4A at 240V AC	AC Control circuits and AC Motor Control to 1 HP
P20-A-240	Standard Relay 240V AC Coil	S.P.D.T.	2500VA at 250VAC 300VA at 30VDC	0 to 240 V AC	10A	7.5A at 240V AC 5A at 30V DC	General AC or DC Control
P20-A-24	Standard Relay 24V AC Coil	S.P.D.T.	2500VA at 250VAC 300VA at 30VDC	0 to 240V AC	10A	7.5A at 240V AC 5A at 30V DC	General AC or DC Control

## TESTING

The P20 switch can be tested for electrical function in the following way. With the switch isolated, place a continuity tester across terminals S1 and S2 or C and NO. (Do not use a lamp tester for this, due to the high inrush current.) Use a pencil or similar object to depress the piston. Each time the piston is depressed a closed circuit should appear across S1 and S2 or C and NO. The piston is accessed by pushing the pencil straight down the centre of the switch, through the inlet fitting. This test can be done dry, and without the switch in the pipe-work. Each time the piston is released it should return to the off position, due to the internal magnetic repulsion, and the switch should respond with an open circuit across its terminals.

## MAINTENANCE

This flow switch is a very low maintenance device. If The P20 flow switch is correctly installed and if the process fluid is compatible with the materials of construction of this switch, then a very long service life can be expected. Factors that may contribute to early failure of this device include excess temperature, excess pressure or electrical loads in excess of the electrical modules ratings.

### PARTS LIST FOR P20 IN LINE FLOW SWITCH

All of the components of this switch are available as spare parts, as listed below.

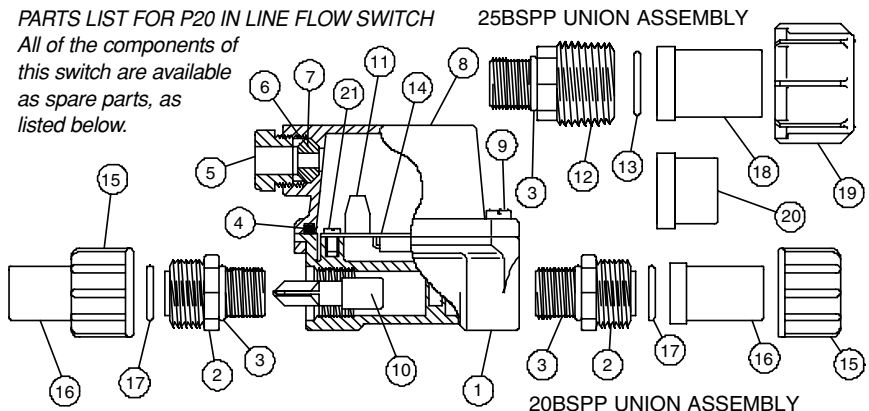

ITEM	DESCRIPTION	QTY	MATERIAL
1	SWITCH BODY	1	GLASS REINFORCED POLYPROPYLENE
2	M20 by 3/4BSPP ADAPTOR	2	GLASS REINFORCED POLYPROPYLENE
3	No 018 O-RING	2	NEOPRENE
4	MAIN LID GASKET	1	SANOPRENE
5	CABLE GLAND NUT	1	HIGH IMPACT ABS
6	CABLE GLAND THRUST RING	1	HIGH IMPACT ABS
7	CABLE GROMMET	1	SANOPRENE
8	LID	1	HIGH IMPACT ABS
9	LID FIXING SCREW	1	M5 BY 16 STAINLESS STEEL TYPE 304
10	PISTON,MODEL A, B or C	1	GLASS REINFORCED POLYPROPYLENE
11	TERMINAL BLOCK	1	ACETAL RESIN
12	M20 by 1" BSPP ADAPTOR	2	GLASS REINFORCED POLYPROPYLENE
13	No 117 O-RING SEAL	2	NEOPRENE
14	CIRCUIT BOARD ASSEMBLY	1	COMPLETE ELECTRICAL MODULE
15	20 mm BSPP UNION NUT	2	GLASS REINFORCED POLYPROPYLENE
16	15 mm (1/2") PIPE SPIGOT	2	PVC OR ABS
17	No 115 O-RING SEAL	2	NEOPRENE
18	20mm (3/4") PIPE SPIGOT	2	PVC OR ABS
19	25mm BSPP UNION NUT	2	GLASS REINFORCED POLYPROPYLENE
20	15mm (1/2") PIPE SOCKET	2	PVC OR ABS
21	CIRCUIT BOARD SCREW	2	M4 BY 6 STAINLESS TYPE 304

MADE IN AUSTRALIA BY

### KELCO ENGINEERING

Manufacturing division of CYNCARD PTY LTD ABN 20 002 834 844  
 Head Office and Factory: 2/9 Powells Road BROOKVALE 2100 AUSTRALIA  
 Postal Address: PO Box 496 BROOKVALE NSW 2100  
 Phone: 61 2 (02) 9905 6425 Fax: 61 2 (02) 9905 6420  
 Email: kelco@wr.com.au

PLEASE NOTE: The "P20" Series In Line Float Switch is the subject of patent and trademark applications both in Australia and internationally.  
 Cyncard Pty Ltd reserves the right to change the specifications of this product without notice.  
 All rights reserved © 2001