

## K SERIES HEAVY DUTY LEVEL REGULATOR

### FEATURES

- LOW DIFFERENTIAL SWITCHING
- ALL DIRECTION TILT ACTION
- S.P.D.T 3 WIRE SINGLE POINT SWITCH
- POLYPROPYLENE & HYPALON CONSTRUCTION
- WIDE RANGE OF CABLE LENGTHS AVAILABLE
- STABLE REPEATABLE SWITCHING ACTION
- NO MERCURY OR LEAD COMPONENTS
- COMPACT SIZE, 75mm DIAMETER
- OPTIONAL CABLE WEIGHT AVAILABLE

### APPLICATIONS

- BASIC LIQUID LEVEL CONTROL
- MULTI POINT LEVEL CONTROL
- SEWERAGE LEVEL CONTROL
- CHEMICAL LEVEL CONTROL
- HIGH & LOW LEVEL ALARMS
- SELF POWERED SIGNALLING
- PUMP PROTECTION

*The K series heavy duty level regulator is a compact three-wire float switch for highly accurate and repeatable single point level sensing and control applications. It is ideal for use in water, sea water and most acids and alkali solutions. It will provide a stable switching action with a very high degree of reliability. The teardrop shape of the float makes it ideal for effluent and sewerage usage, as the float cell has no shoulders or edges for solids to build on. These float switches can be reliably and safely used in potable water systems, as they do not contain hazardous materials such as mercury or lead.*

### OPERATING PRINCIPLE

The K series level regulator houses a heavy ball that is balanced on the actuating arm of a high precision switch. When rising liquid level causes the float to lift and tilt, the centre of gravity of the ball moves away from the actuating axis of the switch and allows it to de-actuate. A falling liquid level allows the float to straighten up and the centre of gravity of the ball shifts back onto the switch causing it to again actuate. This simple reliable action only requires the float to tilt by 45 degrees in any direction for the switch to operate.

### CONSTRUCTION

The K series heavy duty level regulator is constructed from polypropylene and high compliance three core Hypalon cable. The float chamber is a double moulded hermetically sealed cell with a double moulded barrier of solid polypropylene sealing the cable entry. The switch housed within the float cell is a precision single pole double throw device rated at 0 to 240V AC at up to 15 Amps resistive load.

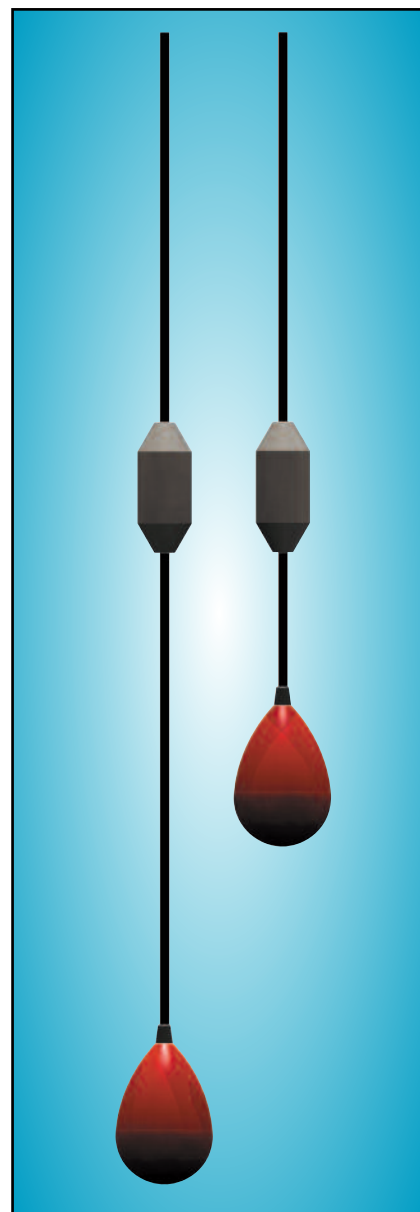

### HAZARDOUS APPLICATIONS

This level regulator is classed as a simple device and does not require separate certification to be used in hazardous applications. In any such installation the level regulator should be isolated by an intrinsically safe barrier, a zener barrier.

### IMPORTANT SAFETY NOTE

The K series level regulators are rated for mains voltage operation. However, in the interest of safety we recommend that they are only ever operated at low voltage, preferably at 24 to 48V AC. Where mains voltage operation is unavoidable an earth leakage circuit breaker should always be installed in the control circuit. The application and wiring of this float switch should always be carried out by qualified electrical personnel and must always conform to local wiring rules.

# TECHNICAL DATA

## CABLE SPECIFICATIONS

<b>Cable type</b>	Heavy Duty EPR/CSP Flexible Hypalon Rubber
<b>Outer sheathing</b>	CSP Hypalon, Oil Resistant & Flame Retarded to VDE 0472
<b>Inner sheathing</b>	R-EP-90 Special Elastomer Insulation
<b>Cores</b>	3 Cores, each 0.75mm Sq. tinned copper
<b>Cable diameter</b>	7.5mm Nominal
<b>Core colours</b>	Blue (Common) Black (Normally Closed) Brown (Normally Open)
<b>Cable voltage rating Uo/U</b>	600 V / 1kV
<b>AC test voltage</b>	2.5kV
<b>Cable current carrying capacity</b>	18 Amps Continuous at a temperature of 30.5°C
<b>Cable maximum tensile strength</b>	30 N
<b>Minimum bending radii</b>	40mm
<b>Maximum ambient operating temperature</b>	80°C
<b>Minimum permissible ambient temperature</b>	-40°C
<b>Minimum permissible ambient temperature for fully flexible operation</b>	-25°C
<b>Cable maximum permissible short circuit temperature</b>	250°C
<b>Standards of cable construction</b>	Meets or exceeds AS1125, AS3191, AS3116 and DIN/VDE0282
<b>Cable lengths available</b>	1, 3, 4, 6, 10, 15, 20, 30, 50 Metres standard. Against special order switches to 1000 Metres can be supplied

## ENVIRONMENTAL LIMITATIONS

<b>Maximum submergence</b>	30meters,300kPa Static pressure
<b>Maximum liquid temperature</b>	60°C
<b>Minimum liquid temperature</b>	-20°C
<b>Liquid specific gravity</b>	>0.82
<b>Liquid Ph</b>	1 to 14
<b>Smallest diameter well that the switch can operate in</b>	Within a 160mm inside diameter vertically mounted pipe
<b>Liquid level change for switch to operate</b>	35mm
<b>Closest switching point to tank floor</b>	50mm
<b>Smallest opening through which the switch will fit</b>	75mm diameter
<b>Minimum distance between float and closest tethering point or cable weight</b>	150mm
<b>Suitability for use in Diesel Fuel</b>	Can be used, but some swelling and softening of the cable & boot may occur
<b>Suitability for use in Sodium Hypochlorite</b>	Fully Compatible
<b>Suitability for sea water use</b>	Fully Compatible
<b>Suitability for use in Octane (Petrol)</b>	Not suitable
<b>Suitability for use in potable water</b>	Fully Compatible

## SWITCH SPECIFICATIONS

<b>Switch type</b>	Single Pole Double Throw
<b>Contact gap</b>	0.5mm
<b>Contact material</b>	Silver Alloy
<b>Contact resistance</b>	15m Ohms (initial value)
<b>Rated voltage AC</b>	0 to 240V AC
<b>Rated voltage DC</b>	0 to 250V DC
<b>Currant rating AC resistive</b>	15 A at 250V AC, 15A at 125V DC
<b>Motor load currant rating AC</b>	1.5 A at 250V AC, 2.5A at 125V AC (1/4HP)
<b>Currant rating DC Resistive</b>	15 Amps at 14V DC, 6 Amps at 30V DC
<b>Maximum lamp load AC</b>	1.25 Amps at 250V AC
<b>Maximum lamp load DC</b>	1.5 Amps at 30V DC
<b>Minimum operating load</b>	100mA at 12V, or 60mA at 24V
<b>Maximum operating frequency, electrical</b>	24 operations per minute
<b>Insulation resistance</b>	100M Ohms minimum at 500 V DC
<b>Dielectric strength between contacts</b>	1000 V AC at 50 to 60Hz for 1 minute
<b>Life expectancy Mechanical</b>	20,000,000 operations minimum
<b>Life expectancy Electrical</b>	500,000 operations minimum
<b>Approved standards</b>	UL508 E41515, CSA C22.2 No55 (File No LR21642)

## OPERATION

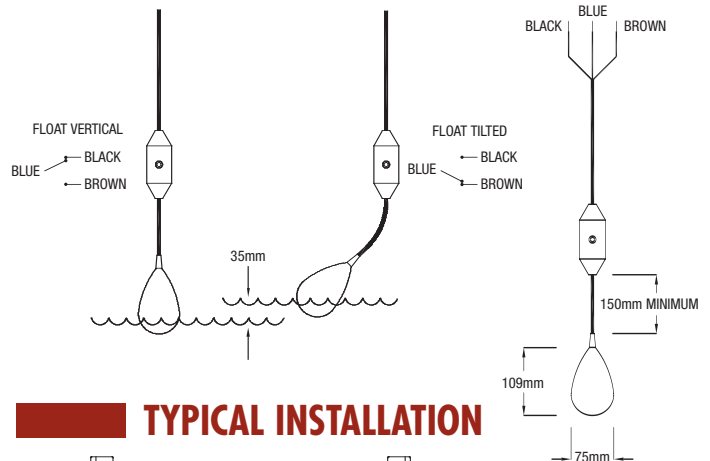

## DIMENSIONS

## TYPICAL INSTALLATION

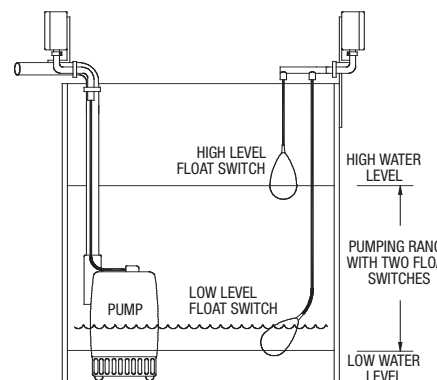

MADE IN AUSTRALIA BY

**KELCO ENGINEERING**

Division of CYNCARD PTY LTD A.B.N. 20 002 834 844

Head Office and Factory: 9/9 Powells Road BROOKVALE 2100 AUSTRALIA

Postal Address: PO Box 496 BROOKVALE NSW 2100

Phone: 61 2 9905 6425 Fax: 61 2 9905 6420

Email: sales@kelco.com.au URL: www.kelco.com.au

PLEASE NOTE: Cyncard Pty Ltd reserves the right to change the specification of this product without notice. Cyncard Pty Ltd accepts no liability for personal injury or economic loss as a consequence of the use of this product. All rights reserved copyright Cyncard Pty Ltd © 2006

# INSTALLATION AND OPERATING INSTRUCTIONS FOR K SERIES HEAVY DUTY LEVEL REGULATOR

**PLEASE READ THIS INSTALLATION SHEET CAREFULLY AND FULLY  
BEFORE INSTALLING THIS FLOW SWITCH**

## APPLICATION

The K series heavy duty level regulator is a low hysteresis tilting float switch capable of providing an on or off signal at a single fixed point in a tank or sump. The low differential switching means the regulator switches when the liquid level reaches it and rises by a further 35mm. If the level then falls by 35mm the switch de-actuates. These float switches are ideal for single point switching applications such as high and low level alarms. Where multiple switching points are required or where a level difference of greater than 35mm is needed multiple float switches should be used.

## HAZARDOUS APPLICATIONS

This float switch is classed as a simple device; it contains no mechanism for the production or storage of electrical energy. As such it requires no separate certification to be used in hazardous environments. For such installations it is necessary to isolate the float switch via an intrinsically safe relay, a zener barrier.

## INSTALLATION

A little care taken when installing this float switch will greatly prolong its service life. Select the installation site carefully. Avoid installing this switch in any area where there is likely to be turbulence or where the float or cable will abrade against tank walls, piping or pumps. Any abrasion between the switch cable and adjacent surfaces will greatly reduce the life of the switch and may cause premature failure. In areas where several float switches are to be installed it is essential to ensure the cable from adjoining switches do not rub or tangle.

Do not install this float switch hard against the side of a tank or pit, to do so limits the free movement of the float and will impede the switching action. Suspend the switch away from tank walls and stand pipes by at least 100mm.

Heavy polypropylene cable weights are available to suit the float switches. If a cable weight was supplied simply clamp the weight onto the cable using the stainless screw provided. Position the weight at least 150mm above the float. Multiple weights can be installed spaced along the switch cable if required.

When tethering the float switch, allow at least 150mm of free cable between the float and the first tethering point. The free cable allows the float to swing and tilt in response to liquid level changes. Flexing of the cable should be distributed evenly along the cable and must not be confined to one point. If the free movement of the cable is restricted it can cause work hardening of the copper strands within the cable and lead to premature failure of the switch.

## ENVIRONMENT

This switch is constructed from polypropylene and hypalon rubber shielded cable. There are no metal parts in contact with the process liquid and this switch can be used in water, sea water, acids, alkalis and a great variety of chemical solutions including oil, oily waste, fats and influents and effluents of many types. The switches can be used in Diesel fuel, but some swelling of the cable may occur.

This float switch should not be used in closed vessels at greater than 300kPa static pressure, or in submerged applications at greater than 30 metres submergence.

Do not expose this switch to liquid temperatures of less than  $-20^{\circ}\text{C}$  or greater than  $+60^{\circ}\text{C}$ . The switch and cable will withstand temperatures outside these limits but the service life may be reduced. Liquids in which this switch is to operate must have a specific gravity of greater than 0.82. In liquids of low specific gravity the buoyancy of the float is reduced and a proportionally higher operating differential results.

Where possible keep the exposed cable out of direct sunlight. For example on top of a tank, terminate the cable in a suitable junction box or run the switch cable inside a length of conduit and do not simply drape the cable over the exposed tank rim. Prolonged exposure to sunlight can perish and crack the cable leading to premature switch failure.

## TYPICAL INSTALLATION

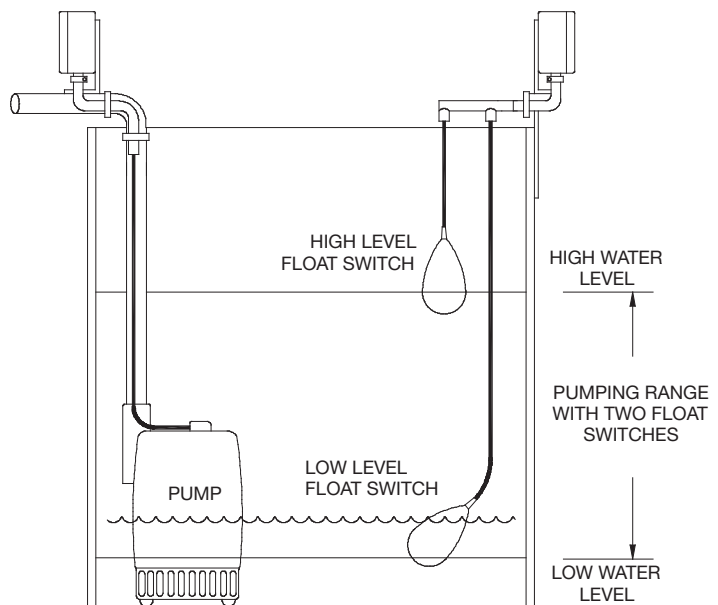

## ELECTRICAL INSTALLATION

All electrical work associated with this float switch must conform to local and national wiring codes and must be carried out by qualified persons only.

### WIRE COLOURS AND FUNCTIONS

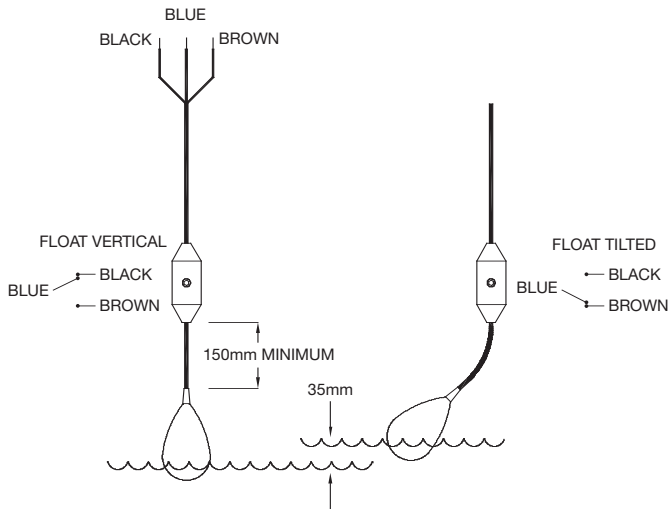

This float switch is rated at 240 VAC, however local regulations may require its use be confined to low voltage control circuits. In the interest of safety we recommend all installations be isolated by a low voltage transformer and operated at 24V to 48V AC. Where it is impractical to use low voltage, all mains voltage installations must incorporate a suitable earth leakage relay.

This float switch houses a single pole double throw switch. The electrical rating of the switch is indicated on the outside face of the float. Connection is via 3-core 0.75mm Hypalon clad cable. With the float hanging vertically the core colours are Blue, Common, Black Normally Closed and Brown Normally Open. When liquid level rises and tilts the float 45° Blue to Brown closes and Blue to Black opens.

As a general guide terminate the float switch well above the liquid high level in the tank or pit. Where possible avoid running the float switch cable any appreciable distance through conduit as this makes servicing, testing or replacement more difficult. Most installations will only require the use of two of the three available wires. This will be the blue common and one of the other two wires. Be aware that when the float switch actuates the unused wire will be live, and it must therefore always be isolated.

## ENVIRONMENTAL LIMITATIONS

Maximum submergence	30meters,300kPa Static pressure
Maximum liquid temperature	60°C
Minimum liquid temperature	-20°C
Liquid specific gravity	>0.82
Liquid Ph	1 to 14
Smallest diameter well that the switch can operate in.	Within a 160mm inside diameter vertically mounted pipe
Liquid level change for switch to operate	35mm
Closest switching point to tank floor	50mm
Smallest opening through which the switch will fit.	75mm diameter
Minimum distance between float and closest tethering point or cable weight	150mm
Suitability for use in Diesel Fuel	Can be used, but some swelling and softening of the cable & boot may occur
Suitability for use in Sodium Hypochlorite	Fully Compatible
Suitability for sea water use	Fully Compatible
Suitability for use in Octane (Petrol)	Not suitable
Suitability for use in potable water	Fully Compatible

### TWO LEVEL TANK CIRCUIT

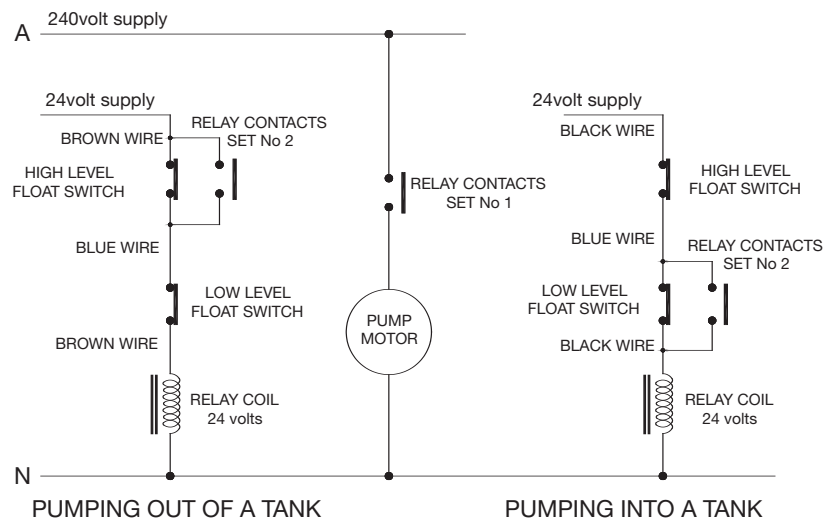

In installations where two float switches are to be used to control the high and low levels in a tank or pit, a latching circuit is normally used. A basic schematic for such a circuit is shown. In the circuit drawing a double pole relay is used to latch the pump on. The latch is broken by either the high or low-level float switch changing state, depending on whether the tank is to be emptied or filled. A suitable relay may be used to directly control a pump motor, however, it is preferable that the control circuit is operated at low voltage and the relay contacts, set 1 be used to control a contactor which in turn controls the pump motor.

MADE IN AUSTRALIA BY

**KELCO ENGINEERING**

Division of CYNCARD PTY LTD A.B.N. 20 002 834 844

Head Office and Factory: 9/9 Powells Road BROOKVALE 2100 AUSTRALIA

Postal Address: PO Box 496 BROOKVALE NSW 2100

Phone: 61 2 9905 6425 Fax: 61 2 9905 6420

Email: sales@kelco.com.au URL: www.kelco.com.au