

D30 SERIES LIQUID LEVEL SWITCH

FEATURES

- FULLY ADJUSTABLE TWO POSITION SWITCHING
- 2 HP RATED 20 AMP S.P.D.T. SWITCH
- NO METAL PARTS IN CONTACT WITH LIQUIDS
- -1 TO 18 BAR PRESSURE RATING
- ALL THERMOPLASTIC CONSTRUCTION
- WEATHERPROOF HOUSING
- SUPER RELIABLE MAGNETIC ACTION
- UNIVERSAL MOUNTING BRACKET SUPPLIED

APPLICATIONS

- SUMP PUMP CONTROL
- FOR EITHER PUMP IN OR PUMP OUT
- WATER TANK LEVEL CONTROL
- EFFLUENT AND LIQUID WASTE LEVEL CONTROL
- SUITS SLURRIES AND HIGH SOLIDS APPLICATIONS
- SEPTIC AND SEWER PUMPOUT CONTROL
- COOLING TOWER CONTROL SYSTEMS
- SUITS FROTHING FOAMING OR AGITATED LIQUIDS
- SUITABLE FOR SEA WATER, ACIDS & MANY CHEMICALS
- WORKS IN SUMPS, PITS, BORES, TANKS, WELLS OR BUNDS
- CAN BE USED IN PRESSURE OR VACUUM VESSELS

Modern thermoplastic piping and tank systems demand modern controls. The D30 level switch is a rugged versatile liquid level switch that integrates states of the art magnet technology with one of the most fundamental principles of physics to achieve a sensible and reliable solution to the problem of controlling the level of liquids in tanks and sumps.

OPERATING PRINCIPLE

The D30 two position top entry level switch operates on the principle of displacement. When non floating solid polypropylene displacers, suspended from the switch, are immersed in liquid their weight is reduced by an amount equal to the weight of the liquid they displace, This weight change is detected and used to actuate a magnetically isolated switch. Surface agitation, froth, floating or submerged solids do not effect the action of the D30 switch. The displacement principle depends on the specific gravity of the liquid in which the displacers are suspended. The switch is set to operate in water, at a specific gravity of 1+/- 5%. Various displacers are also available to allow the switch to operate in liquids of other specific gravities.

CONSTRUCTION

The electrical housing and body of the D30 level switch are constructed from impact resistant ultraviolet stabilized ABS thermoplastic. The solid displacers are made from glass-reinforced polypropylene, and the suspension cord is made from virgin polypropylene. On the underside of the switch body is a standard 20 NB (pipe size) male spigot. The spigot can be either fitted into, or glued into any standard PVC or ABS pipefitting such as flanges, unions or reducing bushes. In addition each switch is supplied with a universal mounting bracket suitable for direct fixing to walls, tank lids or horizontal pipework. The displacers suspended from the switch fit easily inside 50mm nominal size PVC pipe. This feature allows the switch to be simply and quickly mounted in stilling wells, by-pass housings or in stand off risers. Such mounting can be constructed from standard off the shelf PVC or ABS pipe and fittings. The D30 level switch has no metal



AUSTRALIAN MADE

TECHNICAL DATA

parts that come into contact with liquids, regardless of the mounting method used. The actuation arm operates the switch by magnetic force, through a solid barrier of ABS. This means the switch can be used in pressure vessels or in applications where the entire displacer and cord assembly are under pressure or vacuum.

HAZARDOUS AREA USES

The D30 liquid level switch is a mechanically self-actuating device in which there is no mechanism for the production or storage of electrical energy. As such the D30 is classed as a simple device. No separate certification is required to use the switch in an explosion prone environment. In hazardous applications, the switch should be isolated via an intrinsically safe relay, a zenner barrier.

APPLICATIONS

The D30 level switch is designed to detect a level change in liquids that have a specific gravity of one, that is, water or water that contains dissolved or suspended solids. The switch can be mounted in any location above the liquid being sensed. The twist lock displacers are positioned on the cord at points where the switch is required to change state, for example close to the bottom of a tank for the low level switching point and close to the top of a tank for the high level switching point. A falling liquid level will trip the switch when the bottom displacers are partly uncovered, and a rising liquid level will reset the switch when the top displacers are partly submerged. A 20 Amp single pole double throw switch is provided so circuits can be switched on or off when liquid is either rising or falling, making the switch ideal for both pump in and pump out applications. The switch mechanism built into the D30 is a special high current high capacity device, capable of directly controlling pump motors up to 2 HP at 240 VAC. For less demanding applications, the switch is equally capable of actuating relays, contactors or PLC's.

OPERATING PARAMETERS

Minimum level differential	150mm, (with 3 displacers stacked tightly together)
Maximum level differential	20 Metres, (3 Metres of cord supplied with switch)
Minimum distance from switch point to floor of a tank or sump.	40mm (Sumps can be pumped out to within 40mm of floor)
Maximum pressure, at ambient temperature	18 Bars (Where the displacers are in a pressure vessel)
Minimum burst pressure, at ambient temperature	80 Bars
Minimum pressure	-1 Bar (Where the displacers are under vacuum)
Maximum liquid temperature, (in open tank non pressure applications)	100°C (Displacers & cord only can withstand this temperature.)
Maximum liquid temperature, (where switch housing is exposed to hot liquid), at Ph 7	60°C (This temperature must be de-rated in pressure vessel applications.)
Ph Range	1 to 14 (At ambient temperature)
Specific Gravity of process liquid	1.0 +/- 5%
Ingress Protection rating (Housing)	IP 67

Some suggested methods of mounting the D30 Level Switch.

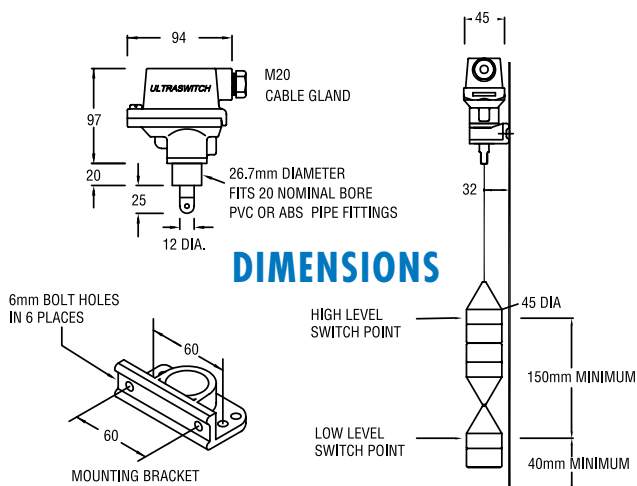
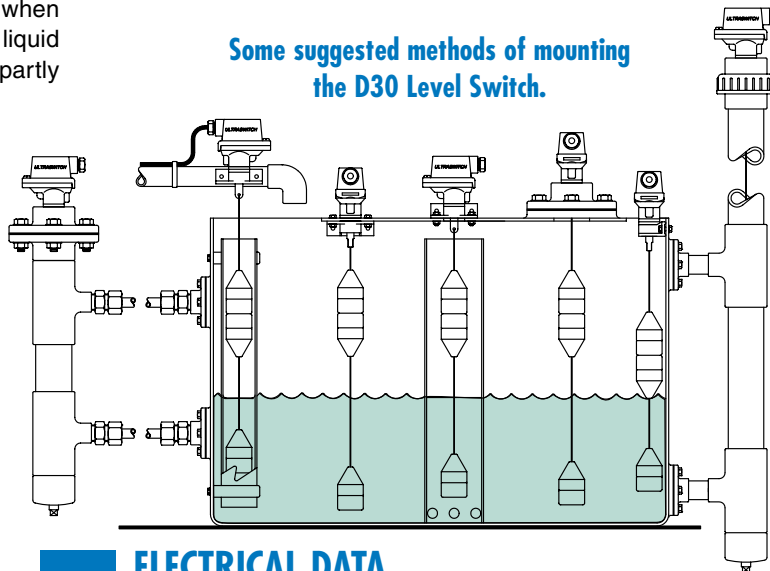

DIMENSIONS

ELECTRICAL DATA

The D30 level switch contains a high capacity single pole double throw microswitch with Tungsten contacts, specifically designed to control motor loads up to 2 Horse Power.

Rated Voltage	NON INDUCTIVE LOADS				INDUCTIVE LOADS			
	Resistive load		Lamp Load		Inductive Load		Motor Load	
	NC	NO	NC	NO	NC	NO	NC	NO
125 VAC	20 A		7.5 A		20 A		12.5 A	
250 VAC	20 A		7.5 A		20 A		8.3 A	
500 VAC	15 A		4 A		10 A		2 A	
8 VDC	20 A		3 A	1.5 A	20 A		12.5 A	
14 VDC	20 A		3 A	1.5 A	15 A		12.5 A	
30 VDC	6 A		3 A	1.5 A	5 A		5 A	
125 VDC	0.5 A		0.5 A		0.05 A		0.05 A	
250 VDC	0.25 A		0.25 A		0.03 A		0.03 A	

MADE IN AUSTRALIA BY

KELCO ENGINEERING

Division of CYNCARD PTY LTD A.B.N. 20 002 834 844

Head Office and Factory: 9/9 Powells Road BROOKVALE 2100 AUSTRALIA

Postal Address: PO Box 496 BROOKVALE NSW 2100

Phone: 61 2 9905 6425 Fax: 61 2 9905 6420

Email: sales@kelco.com.au URL: www.kelco.com.au

PLEASE NOTE: The Ultraswitch D30 Level Switch is the subject of patent and trademark applications both in Australia and abroad.

Cyncard Pty Ltd reserves the right to change the specification of this product without notice. Cyncard Pty Ltd accepts no liability for personal injury or economic loss as a consequence of the use of this product. All rights reserved copyright Cyncard Pty Ltd © 2002.

INSTALLATION AND OPERATING INSTRUCTIONS FOR ULTRASWITCH D30 DISPLACEMENT LEVEL SWITCH

INTRODUCTION

The D30 top entry level switch is a two position level regulator capable of controlling both the high and low level switching points of a pump or contactor set to pump liquid in or out of a pit or tank. The D30 level switch operates by Archimedes Principle. When an object is immersed in liquid its weight is reduced by an amount equal to the weight of the liquid it displaces. In the D30 switch a magnetically actuated microswitch detects the weight change that occurs when liquid submerges a set of solid polypropylene displacers suspended from the switch. Since it is weight change that actuates the switch, specific gravity, or weight per unit volume of the liquid medium is critical to the operation of the switch. The standard D30 level switch is set up to operate in water (with a specific gravity of 1.0 plus or minus 5%). Special displacers are available to suit liquids of other specific gravities.

The actuating arm of the D30 switch is encased in a blind cavity in the switch body. The microswitch in the electrical housing is actuated magnetically through the solid body of the switch. In pressure applications the entire arm and housing can be pressurised with no detrimental effect to the working of the switch. There are no electrical components in contact with the process liquid and no seals or other points of potential failure.

OPERATING ENVIRONMENT

The D30 level switch is an extremely versatile device. It can be used to control the level of liquid in wells, tanks, pits, sumps, bores, or in pressure or vacuum vessels, in fact virtually anywhere liquid is rising or falling in level. It can be used in potable water, distilled water, seawater or water that contains solids, pulp, froth, foam, grit or waste materials. The weatherproof electrical housing of the switch is normally mounted above the liquid to be sensed, and the solid displacers suspended by cord at the points where the rising or falling liquid levels are required to operate the switch. The suspension cord and the displacers are the only components of the switch that come in contact with the liquid, and these are made from inert polypropylene. Polypropylene is highly regarded for its chemical resistance. The specific chemical resistance for Polypropylene can be found in widely available chemical compatibility charts. Essentially the D30 level switch can be used in any liquid of S.G. that does not affect polypropylene, and at any temperature within the limits of tolerance of the displacers and cord.

INSTALLATION

Fig. 1 shows some suggested methods of mounting the D30 switch. These include bracket mounts, pressure vessel mounting and the use of PVC or ABS pipe to fabricate stilling wells or shrouds to house the switch. Whatever method is used, it is critical to the correct operation of the switch that it be mounted absolutely vertically. The switch can be simply mounted in its bracket, or for pressure applications, solvent glued into standard PVC or ABS pipefittings. The displacers are designed to fit down the inside of 50NB PVC class 18 pipe. Such pipe can provide an excellent housing and carrier for the displacer assembly. When glueing the switch into pipefittings, take care not to use excess glue and not to allow glue to make contact with the actuating arm of the switch.

Cord length and the position of the displacers on the cord are fully user adjustable. Take care to ensure the bottom displacers do not touch the bottom of the tank, or the switch will not operate. The standard D30 switch is supplied with 3 metres of cord. Any required cord length can be used with the switch, and the bottom end of the cord should be knotted to prevent the displacers sliding off during adjustment or commissioning.

EXPOSED APPLICATIONS

If this switch is to be mounted in an outside location, for example on top of an open water tank we recommend the switch be mounted in a shroud made from 50mm PVC. A simple pipe shroud, particularly if it is painted will protect the switch from reflected UV sunlight, and thus prevent degradation of the cord and top displacers. This simple precaution will greatly prolong the life of the switch.

Fig 1 Some suggested methods of mounting the D30 Level Switch

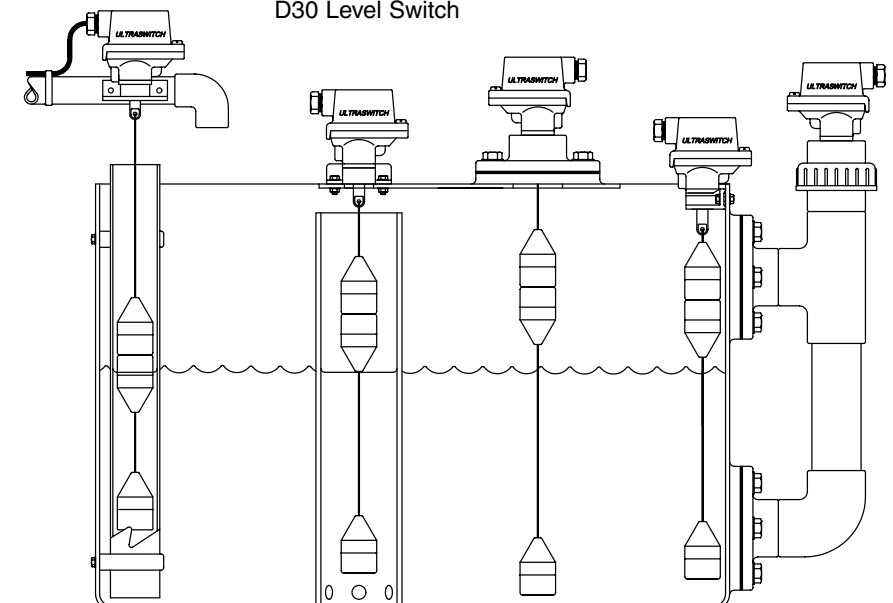

ELECTRICAL

The D30 switch houses a single pole double throw microswitch. Details of the layout of the switch and the terminal designation are shown in the sketch. On a rising liquid level Common to Normally open is closed and Common to Normally Closed is open. On a falling liquid level, the switch reverses state that is Common to Normally open is open and Common to Normally closed is closed. This allows the switch to be configured for either pump out or pump in applications.

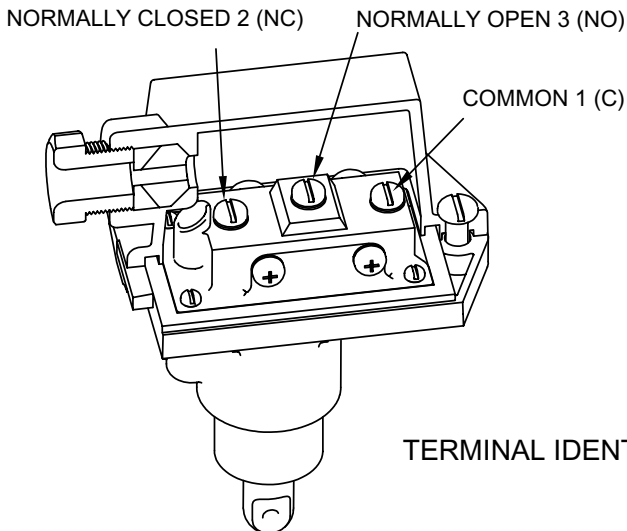

Note

To pump out of a tank, use terminals 1 (C) and 2 (NC)
 To pump into a tank, use terminals 1 (C) and 3 (NO)

MAINTENANCE & ADJUSTMENT

The D30 level switch is supplied pre-set but when required, the switching point in relation to specific gravity is adjustable via an Allen head screw accessed through a port at the end of the microswitch. Under normal circumstances the adjusting screw should not be altered. It is factory set and will only require adjusting if the switch is to be set up to operate in liquids at an SG other than 1.0. When maintenance is required, all components of the D30 level switch are available as spare parts; the body of the switch with the actuating arm included is one complete assembly and is non-serviceable. The actuating arm cannot be removed from the housing.

- 1) THREAD CORD THROUGH THE 3 COMPONENTS
- 2) LAY THE CORD IN THE TRENCH IN THE ANVIL
- 3) SLIDE THE ANVIL INTO THE TOP BODY HALF
- 4) SCREW THE TWO BODY HALVES TOGETHER
- 5) TIE A KNOT IN THE FREE END OF THE CORD

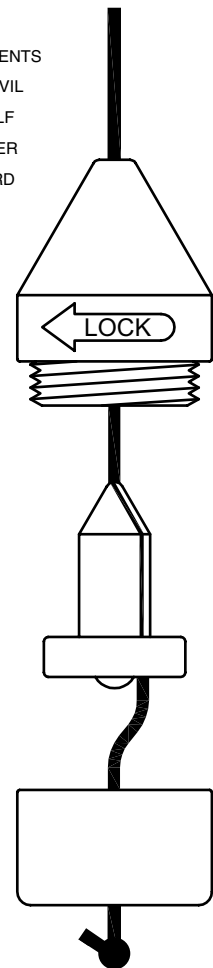

Fig 2 DISPLACER ASSEMBLY

ELECTRICAL DATA

The D30 level switch contains a high capacity single pole double throw microswitch with Tungsten contacts, specifically designed to control motor loads up to 2 Horse Power.

Rated Voltage	NON INDUCTIVE LOADS				INDUCTIVE LOADS			
	Resistive load		Lamp Load		Inductive Load		Motor Load	
	NC	NO	NC	NO	NC	NO	NC	NO
125 VAC	20 A		7.5 A		20 A		12.5 A	
250 VAC	20 A		7.5 A		20 A		8.3 A	
500 VAC	15 A		4 A		10 A		2 A	
8 VDC	20 A		3 A	1.5 A	20 A		12.5 A	
14 VDC	20 A		3 A	1.5 A	15 A		12.5 A	
30 VDC	6 A		3 A	1.5 A	5 A		5 A	
125 VDC	0.5 A		0.5 A		0.05 A		0.05 A	
250 VDC	0.25 A		0.25 A		0.03 A		0.03 A	

MADE IN AUSTRALIA BY **KELCO ENGINEERING**

Manufacturing division of CYNCARD PTY LTD A.B.N. 20 002 834 844
 Head Office and Factory: 2/9 Powells Road BROOKVALE 2100 AUSTRALIA
 Postal Address: PO Box 496 BROOKVALE NSW 2100
 Phone: 61 2 (02) 9905 6425 Fax: 61 2 (02) 9905 6420
 Email: sales@kelco.com.au URL: http://www.kelco.com.au

PLEASE NOTE: The Ultraswitch D30 Displacement Level Switch is the subject of patent and trademark applications both in Australia and internationally. Cyncard Pty Ltd reserves the right to change the specifications of this product without notice. All rights reserved © 2002