

C20 SERIES INLINE FLOW SWITCH

FEATURES

- STAINLESS STEEL OR BRASS BODY
- CHOICE OF 3 SWITCHING POINTS
- CHOICE OF 2 ELECTRICAL MODULES
- VERY HIGH PRESSURE RATING
- LOW HEAD LOSS DESIGN
- FULLY SERVICEABLE
- SPARE PARTS AVAILABLE
- WEATHERPROOF

The C20 in line flow switches are compact magnetically actuated piston flow switches that switch in response to low fluid flows. They are ideal for many types of pressure boosting and control applications in both hot and cold liquids. They are available with bodies made from brass or 316 stainless steel.

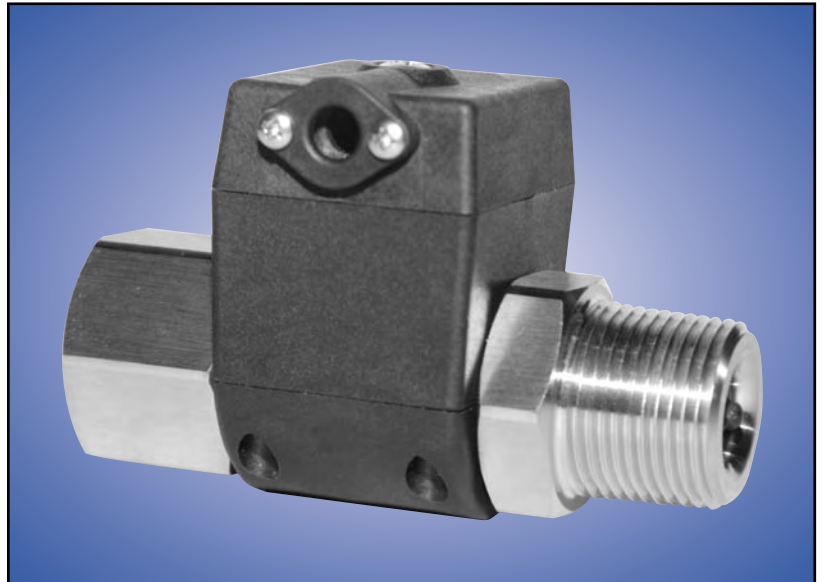

CONSTRUCTION

The C20 flow switch consists of an electrical switching module that saddles a one-piece metal body. The switches are available with a variety of inlet and outlet threads. The electrical modules fitted to the C20 flow switches are easily removed without disturbing pipework, and can be reversed or rotated and positioned to suit tight locations. The switches can handle flows up to 30 Litres per minute, and can tolerate static or dynamic pressures to 100 Bars (1470PSI) with a 4 to 1 safety factor.

FLOW SENSITIVITY

Sensitivity to flow depends on liquid viscosity and piston clearance. There are three pistons available to suit the C20 flow switches. These are designated and marked A, B and C. Switches are normally supplied with one of the three pistons pre-fitted. The table below shows the switch on and switch off flow rates for the three pistons.

Piston Markings	Switching Point on a Slowly Rising Flow in Litres per Minute	Switching Point on a Slowly Reducing Flow in Litres per Minute	Electrical Response Time in Seconds
A	0.140	0.065	0.4
B	0.570	0.370	0.3
C	1.70	1.33	0.2

Note: The data shown in the table above refers to water at ambient temperature as the test medium. Increasing fluid viscosity will decrease the switch on points. Decreasing the fluid viscosity will proportionally increase the switch on points.

INSTALLATION

The flow switches can be positioned in any orientation in pipework. In vertical piping, flow can be either upward or downward through the switch with very little difference in sensitivity. This flow switch is suitable for use with hot or cold liquids up to 90°C. Systems can be steam sterilized at 100°C for short periods without damaging the switch.

HAZARDOUS APPLICATIONS

The C20-B flow switches can be used in hazardous areas. They are classed as simple devices as they do not contain components capable of storing or producing an electric charge. As simple devices the switches can be used in hazardous applications provided they are isolated by an intrinsically safe barrier.



AUSTRALIAN MADE

TECHNICAL DATA

GENERAL LAYOUT

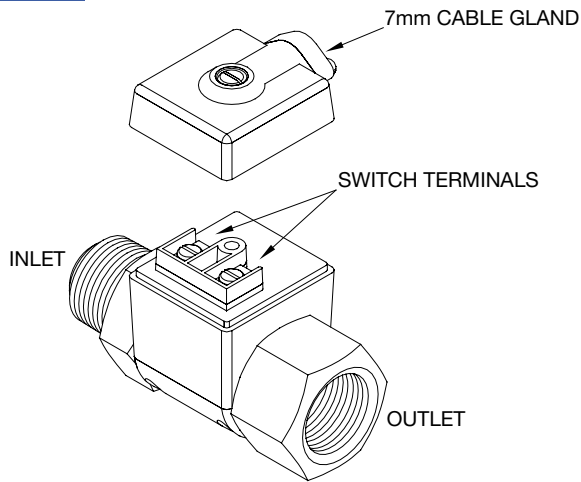

DIMENSIONS

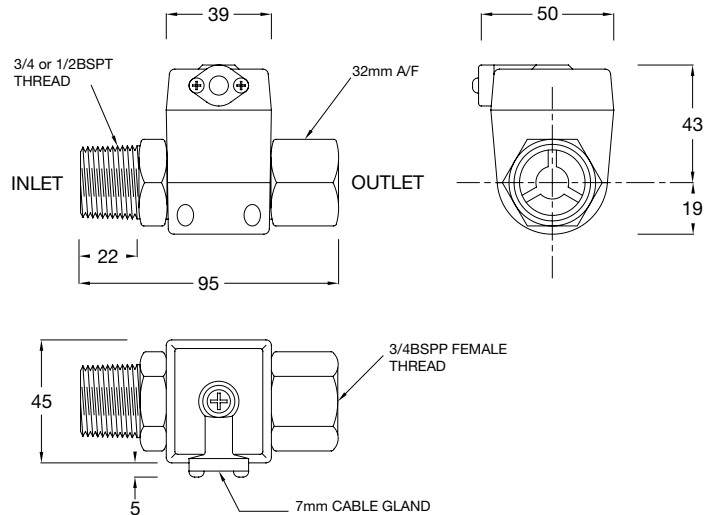

ELECTRICAL DATA

Sensor Model	Module Type	Contact Configuration	Switched Power Maximum	Switched Voltage Maximum	Switch Current Resistive AC (rms)	Inductive Loads (Power Factor 0.4)	Typical Application
B	Dry Reed Switch	S.P.S.T Normally Open	40Watts	240VAC 200VDC	1 Amp Maximum	Not Suitable	PLC Telemetry and Relay Logic circuits
R	Solid State Relay (Triac)	S.P.S.T Normally Open	1.1kW	5 to 240V AC	10mA Minimum 5 Amps Maximum	5 Amps at 240V	AC control circuits and direct motor control

Note: The switched power of the C20-R module given above refers to a switch operating in a water pipe system at ambient temperature. In hot water applications the switched power must be proportionally reduced to avoid overheating the Triac. At the top operating temperature of 90°C the switched power must not exceed 375 Watts. The C20-B modules do not require de-rating at elevated temperatures.

HEAD LOSS VERSUS FLOW RATE

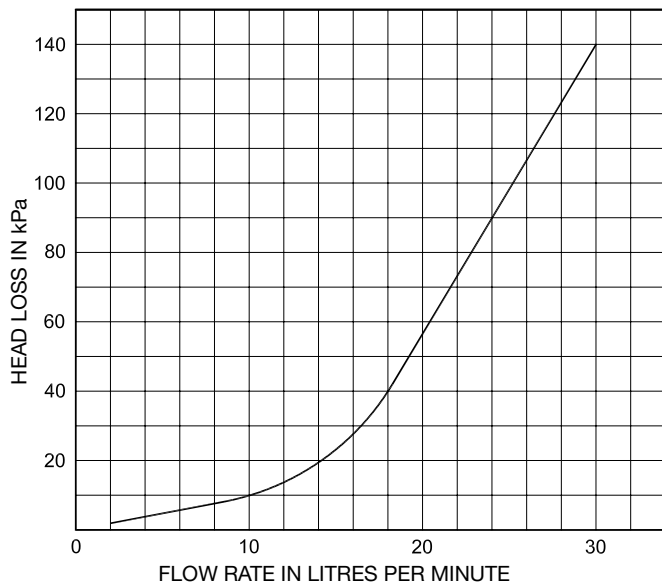

ORDERING

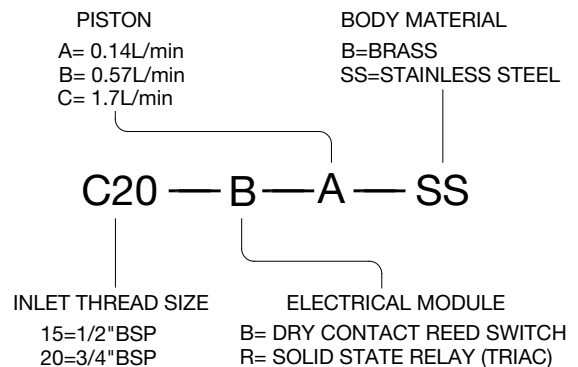

MADE IN AUSTRALIA BY

KELCO ENGINEERING

Division of CYNCARD PTY LTD A.B.N. 20 002 834 844

Head Office and Factory: 9/9 Powells Road BROOKVALE 2100 AUSTRALIA

Postal Address: PO Box 496 BROOKVALE NSW 2100

Phone: 61 2 9905 6425 Fax: 61 2 9905 6420

Email: sales@kelco.com.au URL: www.kelco.com.au

PLEASE NOTE: Cyncard Pty Ltd reserves the right to change the specification of this product without notice. Cyncard Pty Ltd accepts no liability for personal injury or economic loss as a consequence of the use of this product. All rights reserved copyright Cyncard Pty Ltd © 2005

KELCO C20 FLOW SWITCH INSTALLATION AND OPERATION

The C20 inline flow switch is a compact magnetically actuated piston flow switch that is normally off and switches on in response to fluid flow. It is suitable for many types of pressure boosting and control applications in both hot and cold liquids.

INSTALLATION

The C20 flow switch can be installed in any location in vertical or horizontal pipes. In vertical pipes flow can be either upward or downward through the switch. Where possible, install a union on the inlet and outlet of the flow switch to allow easy removal for cleaning and servicing. Ensure the flow switch is oriented correctly to direction of flow. The male threaded end of the switch is the inlet. When installing, make sure no thread tape or other foreign matter from the installation becomes entrained in the switch. Also ensure no foreign matter can enter the flow switch from tanks or pipework. Where scale or other material may be present always install a Y-strainer in the inlet pipe directly before the switch. The electrical module that saddles the flow switch body can be removed if required to allow the body of the switch to be screwed into tight locations, for example into the discharge port of a pump. To remove the electrical module undo the 4 self-tapping screws that secure the two halves of the module together.

REFITTING ELECTRICAL MODULES

The electrical module of the C20 flow switch can be oriented to suit the application. It can be mounted in either direction on the switch body and can be rotated around the switch body to any required position. All modules are normally off switches that turn on in response to flow. Reversing the orientation of the electrical module does not reverse the action of the switch. To refit a module to the switch body, fit and tighten the 4 stainless self-tapping screws. Do not place any material such as grease, glue or packing material between the electrical module and the switch body, to do so may alter the heat flow characteristics of the switch and possibly lead to overheating or premature failure.

CHECK VALVES

Many applications will benefit from a non-return valve in the pipework directly before the C20 flow switch. The flow switch is not designed to operate as a one-way valve and rapid or high-pressure flow reversal, such as water hammer can damage the piston in the flow switch. A simple non-return valve adjacent to the flow switch will reduce the possibility of damage to the flow switch due to flow reversal.

HOT LIQUIDS

This flow switch is suitable for use with hot or cold liquids up to 90°C. Systems can be steam sterilized at 100°C for short periods without damaging the switch. Note that the continuous switched power of the C20-R model must be linearly reduced at elevated temperatures. See the notes below.

FLOW SENSITIVITY

Sensitivity to flow depends on liquid viscosity and piston clearance. There are three pistons available to suit the C20 flow switches. These are designated and marked A, B and C. Switches are normally supplied with one of the three pistons pre-fitted. The specific piston fitted to the switch is indicated on the label inside the lid of the switch. The table below shows the switch on and switch off flow rates for the three pistons.

Piston Markings	Switching Point on a Slowly Rising Flow in Litres per Minute	Switching Point on a Slowly Reducing Flow in Litres per Minute	Electrical Response Time in Seconds
A	0.140	0.065	0.4
B	0.570	0.370	0.3
C	1.70	1.33	0.2

Note: The data shown in the table above refers to water at ambient temperature as the test medium. Increasing fluid viscosity will decrease the switch on points. Decreasing the fluid viscosity will proportionally increase the switch on points.

ELECTRICAL

The C20 flow switches are available with one of two switching modules. There is an identification number inside the lid of each module that indicates the type. The modules are numbered "B" or "R". The electrical specifications of both models are detailed in the following table.

HAZARDOUS APPLICATIONS

The C20-B flow switches can be used in hazardous areas. They are classed as simple devices as they do not contain components capable of storing or producing an electric charge. As simple devices the switches can be used in hazardous applications provided they are isolated using an intrinsically safe barrier.

ELECTRICAL DATA

Sensor Model	Module Type	Contact Configuration	Switched Power Maximum	Switched Voltage Maximum	Switch Current Resistive AC (rms)	Inductive Loads (Power Factor 0.4)	Typical Application
B	Dry Reed Switch	S.P.S.T Normally Open	40Watts	240VAC 200VDC	1 Amp Maximum	Not Suitable	PLC Telemetry and Relay Logic circuits
R	Solid State Relay (Triac)	S.P.S.T Normally Open	1.1kW	5 to 240V AC	10mA Minimum 5 Amps Maximum	5 Amps at 240V	AC control circuits and direct motor control

Note: The switched power of the C20-R module given above refers to a switch operating in a water pipe system at ambient temperature. In hot water applications the switched power must be proportionally reduced to avoid overheating the Triac. At the top operating temperature of 90°C the switched power must not exceed 375 Watts. The C20-B modules do not require de-rating at elevated temperatures.

GENERAL LAYOUT

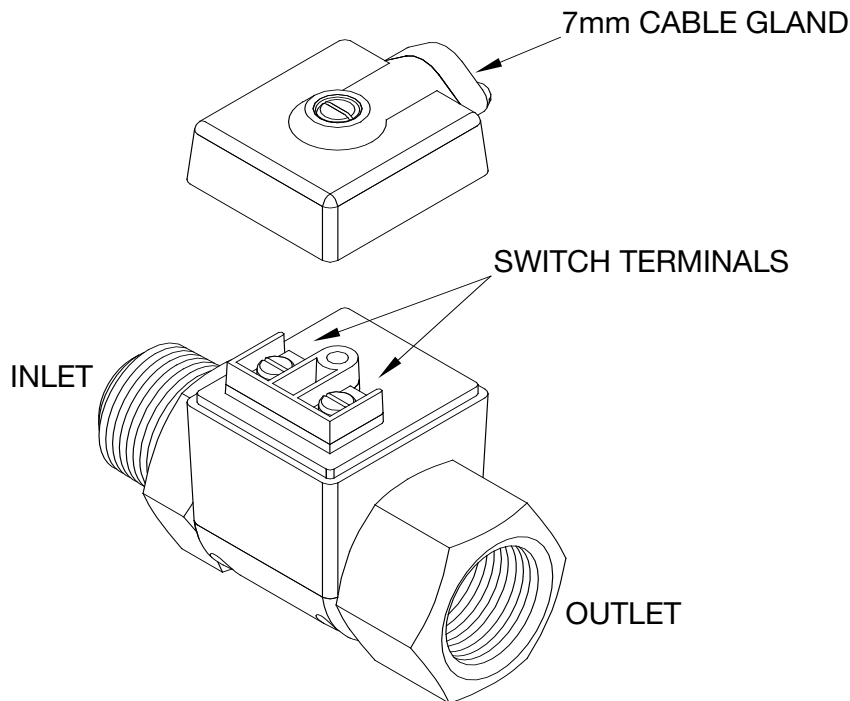

MADE IN AUSTRALIA BY

KELCO ENGINEERING

Division of CYNCARD PTY LTD A.B.N. 20 002 834 844

Head Office and Factory: 9/9 Powells Road BROOKVALE 2100 AUSTRALIA

Postal Address: PO Box 496 BROOKVALE NSW 2100

Phone: 61 2 9905 6425 Fax: 61 2 9905 6420

Email: sales@kelco.com.au URL: www.kelco.com.au

PLEASE NOTE: Cyncard Pty Ltd reserves the right to change the specification of this product without notice. Cyncard Pty Ltd accepts no liability for personal injury or economic loss as a consequence of the use of this product. All rights reserved copyright Cyncard Pty Ltd © 2005